

# ANTI WAVE POOL PRODUCTS

## "ULTIMATE" STORAGE REEL Specifications Sheet

### STORAGE REEL SPECIFICATIONS

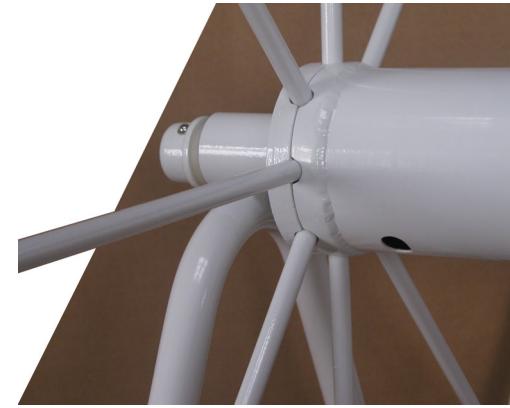
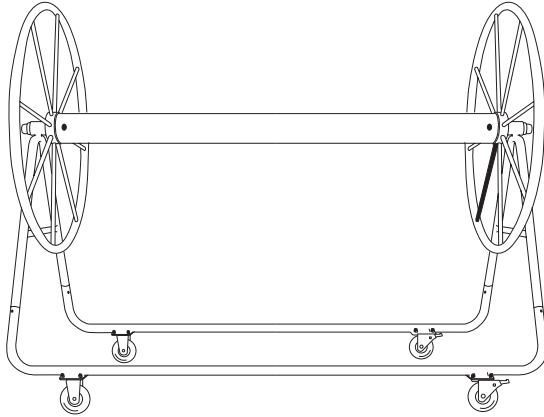

The "Ultimate" Storeel is a high-capacity storage unit for swimming racing lanes. It is of white powder coated, all aluminum construction. The center spool's diameter is 6", designed specifically to minimize damage to the discs when removing lanes from the pool. The "Ultimate" is mounted on four 5" casters, all of which rotate and have brakes attached. Its capacity is seven 25m 4Runner or four 25m 6" lanes. A protective mesh cover is sold separately.

*The "Ultimate" Storage Reel is supported by a 3-year warranty.*

### FRONT VIEW / PRINCIPAL DIMENSIONS

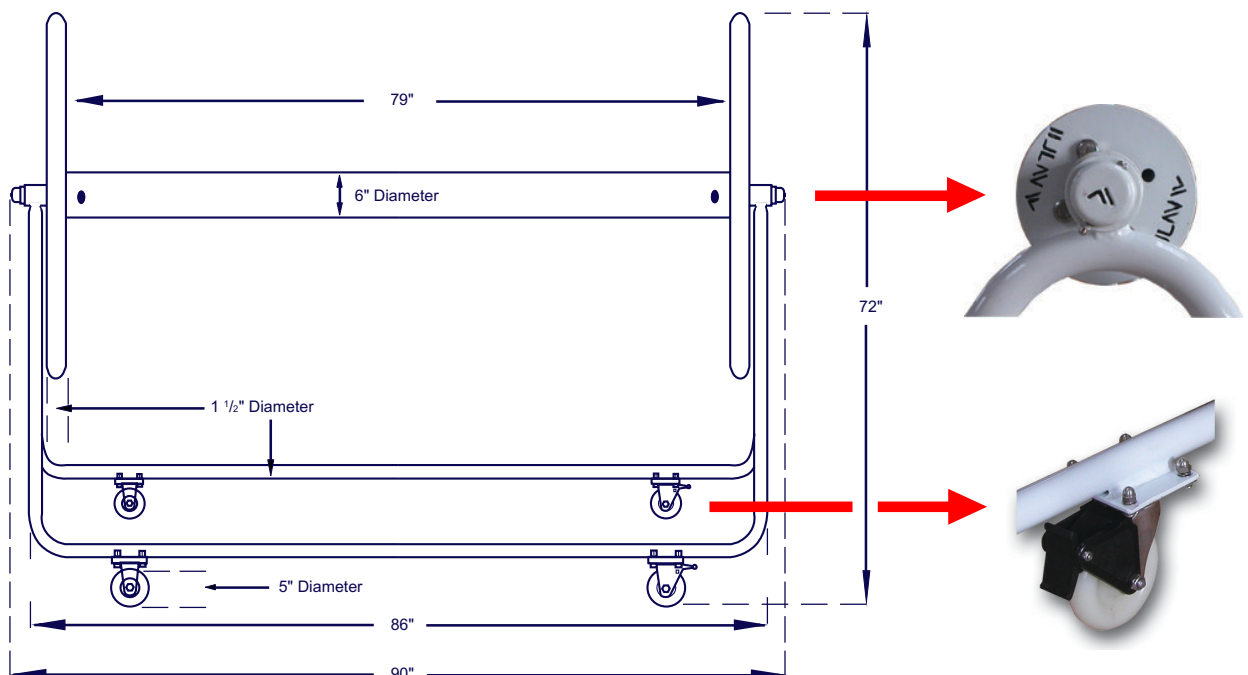

**ANTI WAVE** POOL PRODUCTS "Simply the Best"

1144 Northwest 53<sup>rd</sup> Street, Seattle, WA 98107

Tel: 206.676.8209 Fax: 206.784.9708 [www.antiwave.com](http://www.antiwave.com)



# ANTI WAVE POOL PRODUCTS

## "ULTIMATE" STORAGE REEL Specifications Sheet

### SIDE VIEW / PRINCIPAL DIMENSIONS

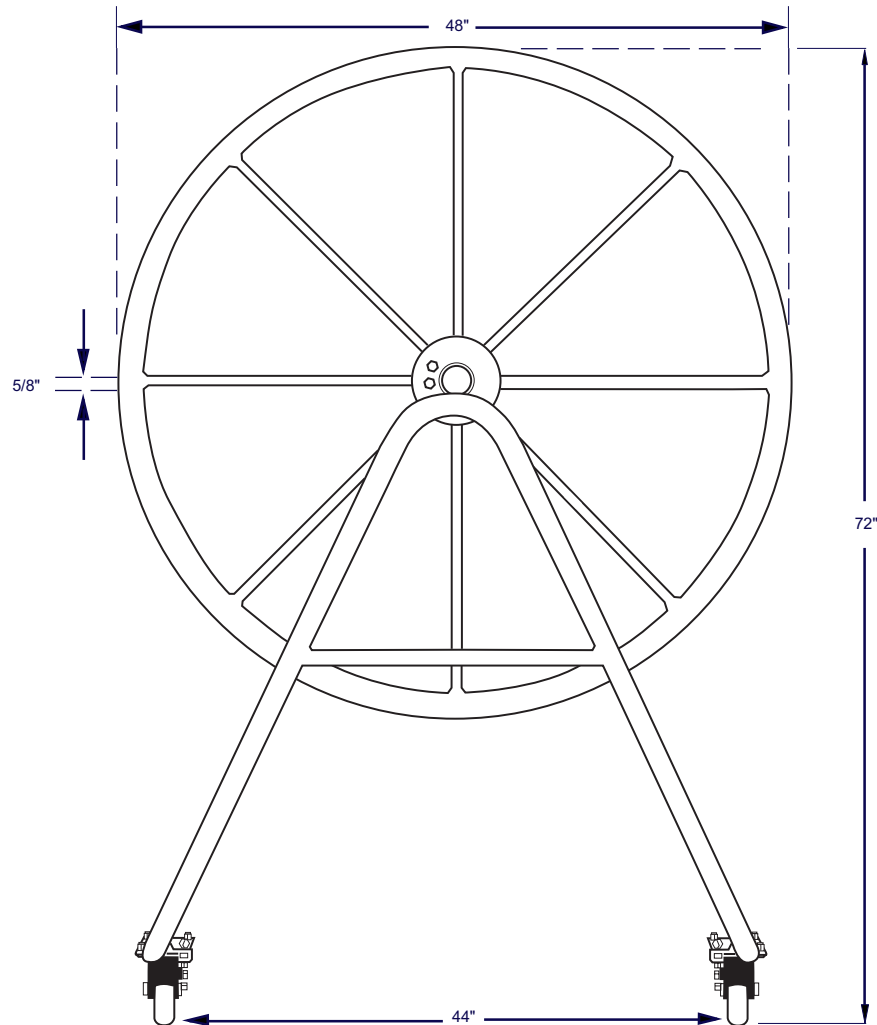

The "Ultimate" Storage Reel is large enough to hold a full set of lanes and has unrivalled capacity. The 6'7" long center spool has a diameter of six inches, designed to eliminate the possibility of damage to the discs.



### SHIPPING SPECIFICATIONS

<b>AW0615</b>	"Ultimate" Storage Reel:	106#	(3 cartons, will ship by truck)
<b>AW0691</b>	"Ultimate" Storage Cover:	9#	(1 carton, will ship by UPS)
<b>AW0615 &amp; AW0691</b>	Shipped together:	113#	(3 cartons, will ship by truck)



**ANTI WAVE** POOL PRODUCTS "Simply the Best"

1144 Northwest 53<sup>rd</sup> Street, Seattle, WA 98107

Tel: 206.676.8209 Fax: 206.784.9708 [www.antiwave.com](http://www.antiwave.com)

